





DIMENSION IN mm [inch]		C		 廣茂股份有限公司 COMMA ELECTRONIC INC.	
TOLERANCE UNLESS OTHERWISE SPECIFIED		名稱 TITLE xD Card Housing Assembly		CUSTOMER DRAWING	
.X±0.3	X'±1"	案 號 FILE NO. XDHD.00	圖 號 DWG NO. XDHD.00-XXXX		
.XX±0.20	.X'±0.5"	圖 紙 SIZE A4	角 法 PROJ. 	日 期 DATE 3/19/09	
.XXX±0.100	.XX'±0.25"	製 圖 DRAW	比 例 SCALE 1:1	更 改 REV XA	



DIMENSION IN mm [inch]		C		 廣茂股份有限公司 COMMA ELECTRONIC INC.	
TOLERANCE UNLESS OTHERWISE SPECIFIED		名稱 TITLE xD Card Top Housing		CUSTOMER DRAWING	
.X±0.3	X'±1"	審核 APPROVE	案 號 FILE NO. XDHD.00	圖 號 DWG NO. XDHD.00-XXXT	
.XX±0.20	.X'±0.5"	核 對 CHECK	圖 紙 SIZE A4	角 法 PROJ. 	日 期 DATE 3/19/09
.XXX±0.100	.XX'±0.25"	製 圖 DRAW	比 例 SCALE 1:1	更 改 REV XA	

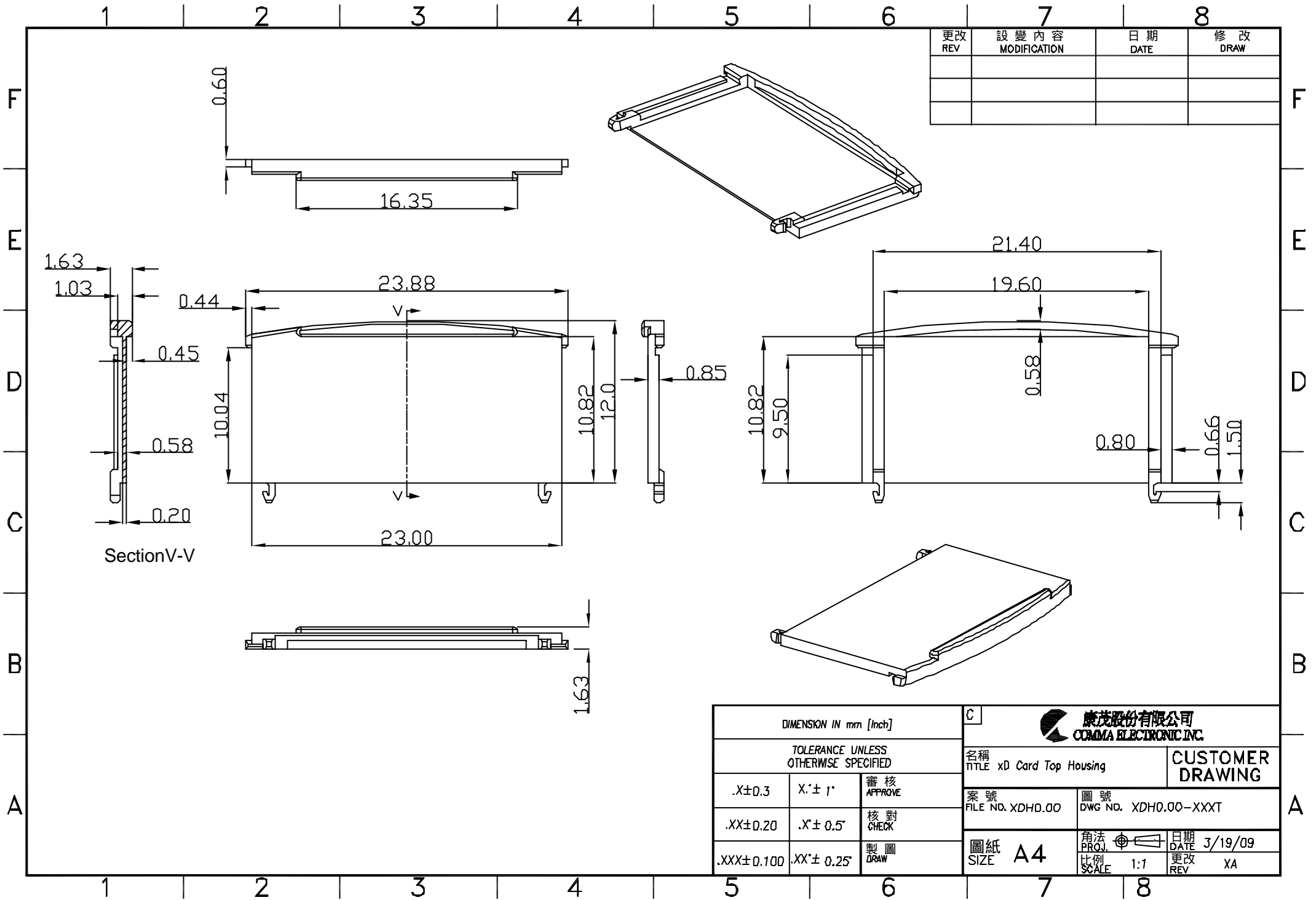