

更改 REV	設變內容 MODIFICATION	日期 DATE	修改 DRAW

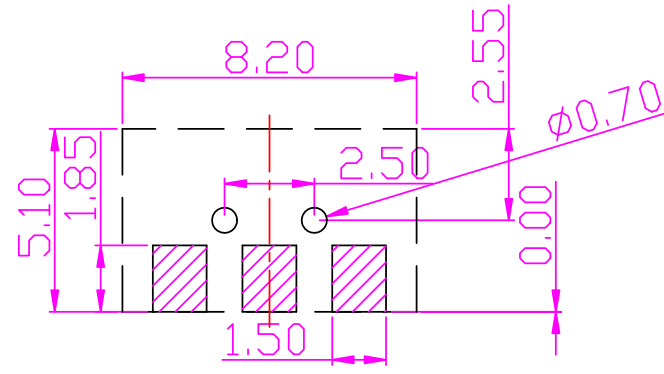

P.C.B. Layout Recommand

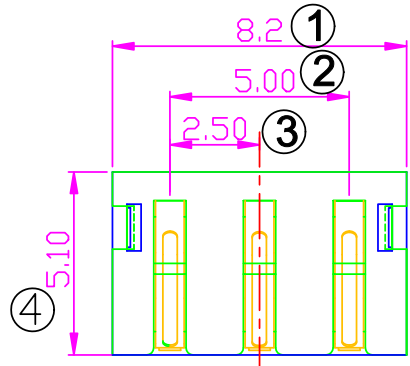
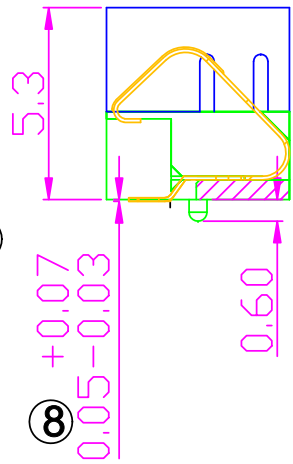
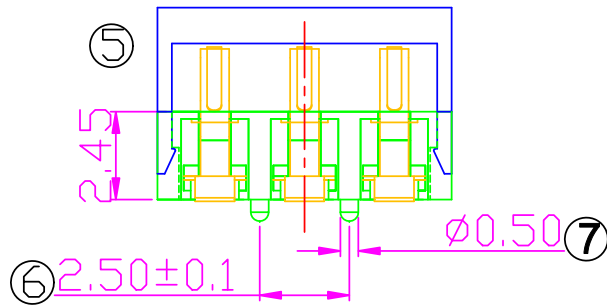

233GRAMMIN
工作行程 293GRAMMAX

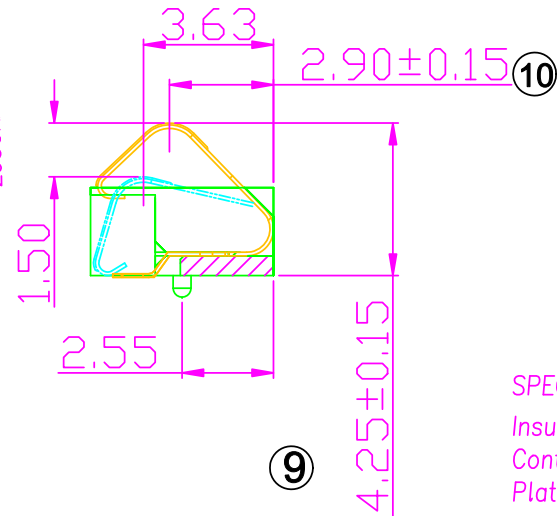

SPECIFICATION
 Insulator : LCP(Black)
 Contact : Beryllium Copper
 Plating : Selected 30u" gold over nickel

DIMENSION IN mm [Inch]				
TOLERANCE UNLESS OTHERWISE SPECIFIED			名稱 BATTERY_CONN._PITCH_2.5MM TITLE 3PIN_HEIGHT_2.45MM CUSTOMER DRAWING	
.X±0.2	X'± 1"	審核 APPROVE	案號 FILE NO. BCS2.5-2103	圖號 DWG No. BCS2.5-2103
.XX±0.10	.X'± 0.5"	核對 CHECK	圖紙 SIZE A4	角法 PROJ. 張數 SHEET 1 / 1
.XXX±0.05	.XX'± 0.25"	製圖 DRAW Ellis	比例 SCALE 1:1	更改 REV A

1 2 3 4 5 6 7 8

更改 REV	設變內容 MODIFICATION	日期 DATE	修改 DRAW

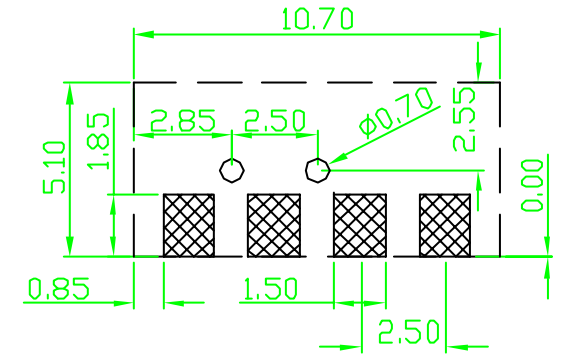
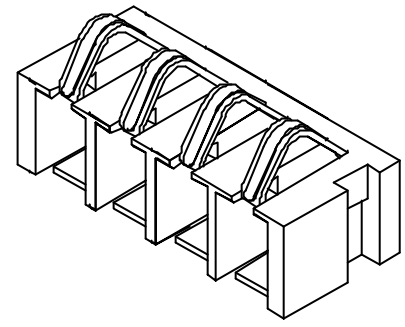
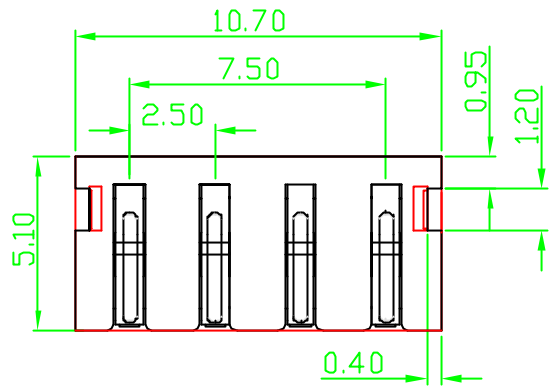

P.C.B LAYOUT (TOP VIEW)

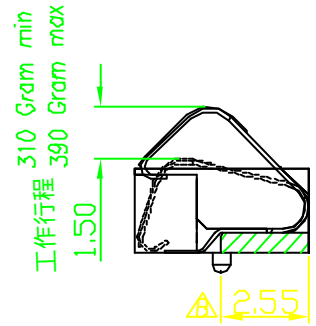
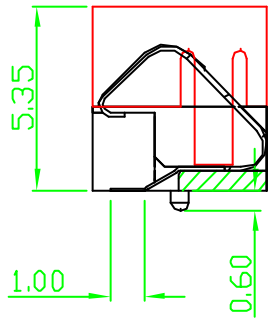
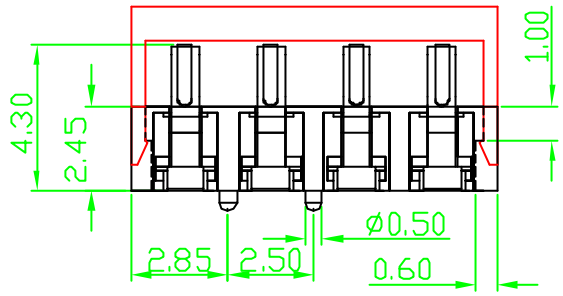

SPECIFICATION
 Insulator : LCP(Black)
 Contact : Beryllium Copper
 Plating : Selected 30u" gold over nickel

F
E
D
C
B
A

F
E
D
C
B
A

1 2 3 4 5 6 7 8

DIMENSION IN mm [Inch]			康茂股份有限公司 COMMA ELECTRONIC INC.	
TOLERANCE UNLESS OTHERWISE SPECIFIED			名稱 TITLE	CUSTOMER DRAWING
.X \pm 0.3	X' \pm 1'	審核 APPROVE	BATTERY CONN. PITCH 2.5mm 4 PIN HEIGHT 2.40mm	
.XX \pm 0.20	.X' \pm 0.5'	核對 CHECK	案號 FILE NO.	圖號 DWG NO.
.XXX \pm 0.100	.XX' \pm 0.25'	製圖 DRAW	BCS2.5-2104	BCS2.5-2104
			圖紙 SIZE	角法 PROJ.
			A4	張數 SHEET
				1 / 1
				更改 REV
				B
			比例 SCALE	
			1:1	

更改 REV	設 變 內 容 MODIFICATION	日 期 DATE	修 改 DRAW
B	肋條和SMT修短	92,02,20	MK LEE
C	COVER修改	92,06,20	MK LEE

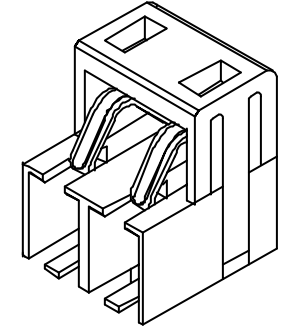
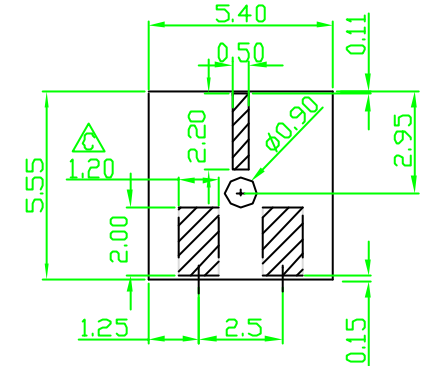
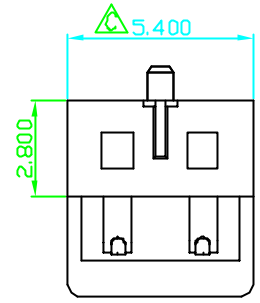

P.C.B. LAYOUT (TOP VIEW)

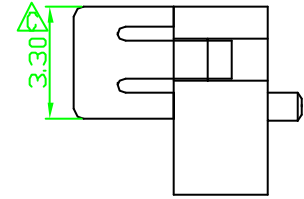
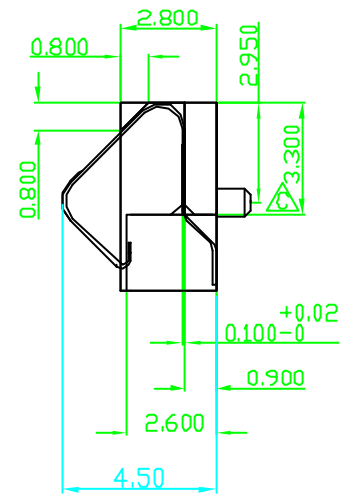
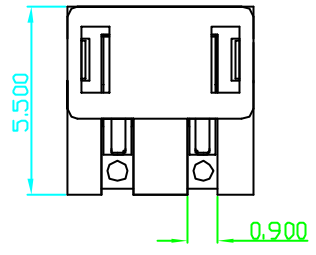

SPECIFICATION

Insulator : LCP(Black)
 Contact : Beryllium Copper
 Plating : Selected 307" gold over nickel

STANDARD DATA

Rating current : 1.0A
 Operating temperature : -30? ~ +70?
 Storage temperature : -40? ~ +85?

ELECTRICAL

Insulator resistance : 1000M ohms Min. @ 250 VDC
 Withstanding voltage : 250VAC / minute
 Contact resistance : 50 m ohms Max.

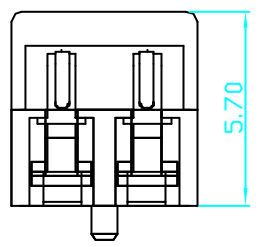

DIMENSION IN mm [Inch]			 廣茂股份有限公司 COMMA ELECTRONIC INC.	
TOLERANCE UNLESS OTHERWISE SPECIFIED			名稱 TITLE	CUSTOMER DRAWING
.X±0.3	X'± 1"	審核 APPROVE	案 號 FILE NO.	圖 號 DWG NO.
.XX±0.20	.X'± 0.5"	核 對 CHECK	BCS2.5-1102	BCS2.5-1102
.XXX±0.100	.XX'± 0.25"	製 圖 DRAW	圖紙 SIZE	角法 PROJ.
			A4	張數 SHEET 1 / 1
			比例 SCALE 1:1	更改 REV C

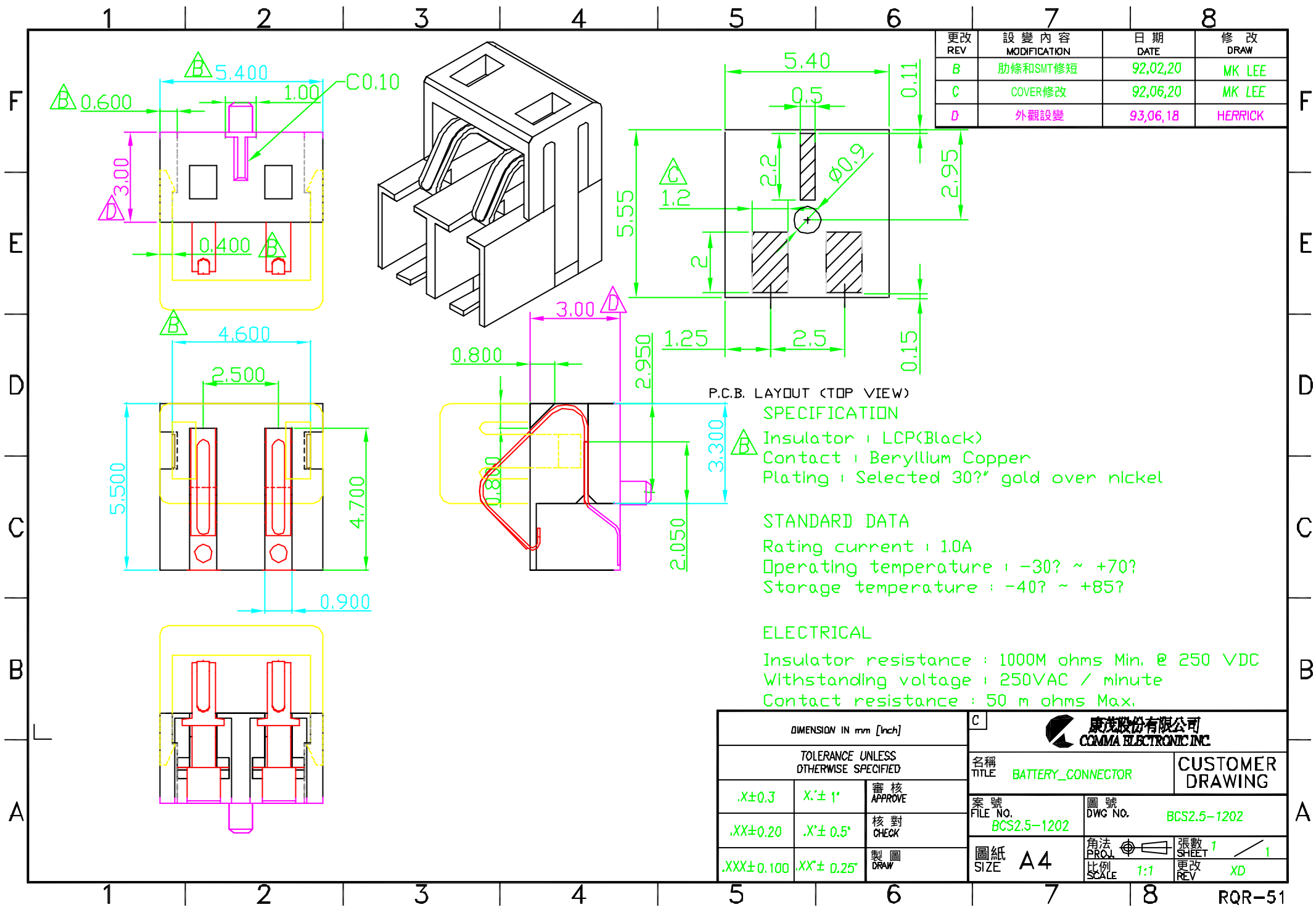

更改 REV	設 變 內 容 MODIFICATION	日 期 DATE	修 改 DRAW
B	肋條和SMT修短	92,02,20	MK LEE
C	COVER修改	92,06,20	MK LEE
D	外觀設變	93,06,18	HERRICK

DIMENSION IN mm [Inch]		
TOLERANCE UNLESS OTHERWISE SPECIFIED		
.X±0.3	X'±1'	審 核 APPROVE
.XX±0.20	.X'±0.5'	核 對 CHECK
.XXX±0.100	.XX'±0.25'	製 圖 DRAW

 康茂股份有限公司 COMMA ELECTRONIC INC.		CUSTOMER DRAWING
名稱 TITLE	BATTERY_CONNECTOR	
案 號 FILE NO.	BCS2.5-1202	圖 號 DWG No.
圖 紙 SIZE	A4	角 法 PROJ
		圖 樣 SCALE
		張 數 SHEET
		更 改 REV